

# Theoretical Prediction of Welding Hot Cracking and Its Control<sup>†</sup>

SERIZAWA Hisashi\*

## Abstract

Based on the interface element proposed for crack propagation problems, a finite element method (FEM) with a temperature dependent interface element is developed. The proposed method is applied to the analysis of the formation and propagation of hot cracking in welding. In particular, Houldcroft type test, Trans-Varestraint test and the narrow gap welding are analyzed using the proposed method.

**KEY WORDS:** (Interface Element) (Houldcroft Type Test) (Trans-Varestraint Test) (Narrow Gap Welding) (BTR) (Hot Cracking) (Finite Element Method)

## 1. Introduction

There have been many previous studies on hot cracking. For example, Senda *et al.* proposed a parameter CST (critical strain rate for temperature drop) under Trans-Varestraint test<sup>1)</sup> and Nakata *et al.* conducted Houldcroft type test for examining the BTR (solidification brittleness temperature range)<sup>2)</sup>. Most of the existing reports are experimental and empirical in nature and their mechanistic understanding is not fully developed. So, in this report, a finite element method (FEM) is developed as a tool to clarify theoretically the mechanism of hot cracking from mechanical point of view.

It is impossible to analyze the hot cracking with a simple thermal-elastic-plastic FEM code, since the conventional FEM used for analysis of the deformation and residual stresses caused by welding models volumetric behavior. On the other hand, the hot cracking involves the formation of a new surface. Therefore, in order to analyze the formation and the propagation of hot crack, not only the mechanical behavior of the volume but also that of the surface have to be modeled. Recently, an interface element has been developed based on the understanding that the crack propagation can be considered as the formation of new surfaces<sup>3)</sup>. In this paper, a new temperature dependent interface element is developed and applied to analyze the hot cracking problems.

## 2. Theoretical Formulation

Since the crack is formed when the opening stress exceeds the bonding strength of the grain boundary or the interface, the brittleness of the material at elevated temperature can be modeled through the temperature dependent bonding strength of the interface element. Both the bonding strength and the yield stress are assumed to be temperature dependent and the BTR is modeled as the temperature range in which the bonding strength becomes smaller than the yield stress as shown in Fig.1.

Essentially, the interface element is the distributed nonlinear spring existing between surfaces forming the interface or the potential crack surfaces as shown in Fig.2. The relation between the opening of the interface  $\delta$  and the bonding stress  $\sigma$  is shown in Fig.3. When the opening  $\delta$  is small, the bonding between two surfaces is maintained. As the opening  $\delta$  increases, the bonding

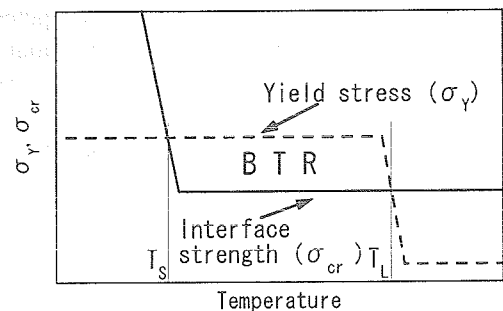

Fig.1 Temperature dependent yield stress and critical stress of interface element.

<sup>†</sup> Received on January 31, 2003  
\* Associate Professor

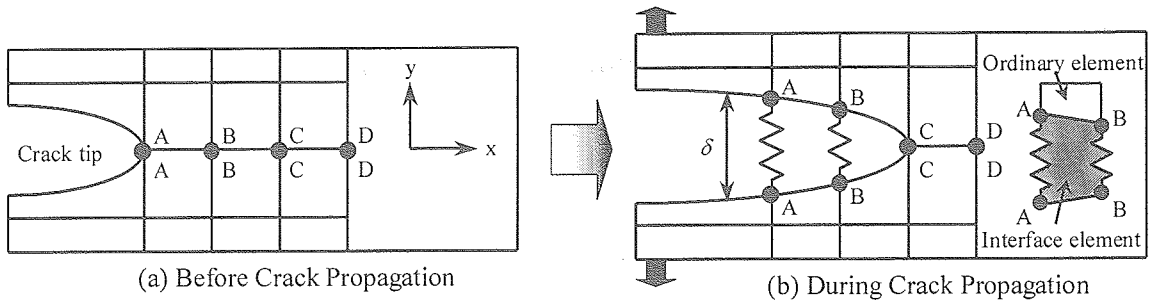

Fig.2 Representation of crack extension using interface element.

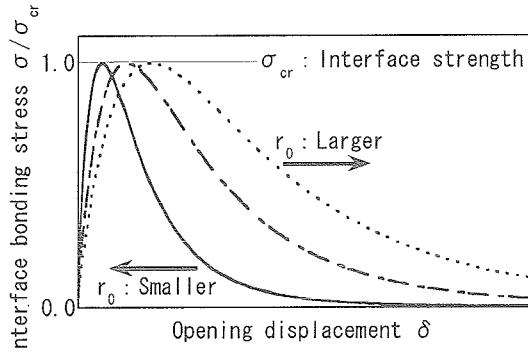

Fig.3 Stress-opening displacement curves of interface element.

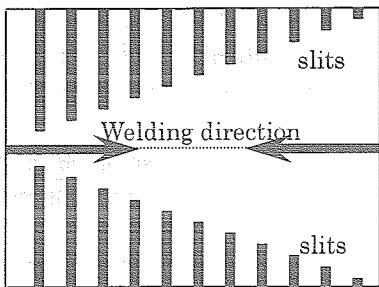

Fig.4 Two types of Fish Bone specimens.

stress  $\sigma$  increases till it becomes the maximum value  $\sigma_{cr}$  at the opening  $\delta_{cr}$ . With further increase of  $\delta$ , the bonding strength is rapidly lost and the surfaces are completely separated. Such interaction between the surfaces can be described by the interface potential. There are rather wide choices for such a potential. The authors employed the Lennard-Jones type potential because it explicitly involves the surface energy  $\gamma$  which is necessary to form new surfaces. For our application to hot cracking problems, the temperature dependency is incorporated into the interface element through the surface energy  $\gamma$ . Thus, the interface potential energy  $\phi$  is defined by the following equation.

$$\phi(\delta, T) = 2\gamma(T) \cdot \left\{ \left( \frac{r_0}{r_0 + \delta} \right)^{2N} - 2 \cdot \left( \frac{r_0}{r_0 + \delta} \right)^N \right\}$$

where,  $\gamma(T)$  is the surface energy per unit area which is temperature dependent, whereas  $N$  and  $r_0$  are constants independent of the temperature. The derivative of  $\phi$  with

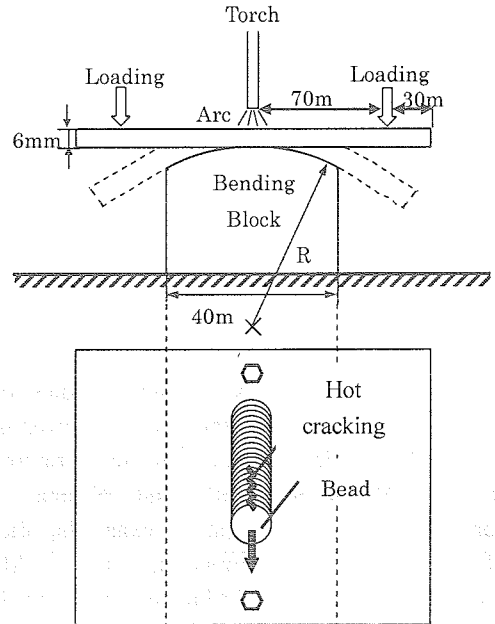

Fig.5 Schematic illustration of Trans-Varestraint test.

respect to the crack opening displacement  $\delta$  gives the bonding stress  $\sigma$  acting on the interface, which has a maximum bonding strength,  $\sigma_{cr}$ , when the opening displacement is  $\delta_{cr}$  as follows.

$$\sigma_{cr}(T) = \frac{4\gamma(T) \cdot N}{r_0} \cdot \left\{ \left( \frac{N+1}{2N+1} \right)^{\frac{N+1}{N}} - \left( \frac{N+1}{2N+1} \right)^{\frac{2N+1}{N}} \right\}$$

$$\delta_{cr} = r_0 \cdot \left\{ \left( \frac{2N+1}{N+1} \right)^{\frac{1}{N}} - 1 \right\}$$

Where  $\sigma_{cr}$  gives the critical strength at temperature  $T$ . Since  $\sigma_{cr}$  is proportional to  $\gamma(T)$ , the temperature dependency of  $\gamma$  is directly reflected in the critical strength  $\sigma_{cr}$ . Thus, the BTR can be modeled through the temperature dependent surface energy  $\gamma$  as shown in Fig.1.

### 3. Simulation

In order to evaluate the hot cracking susceptibility, Houldcroft and Trans-Varestraint tests are widely used. Figures 4 and 5 show schematic illustrations of these

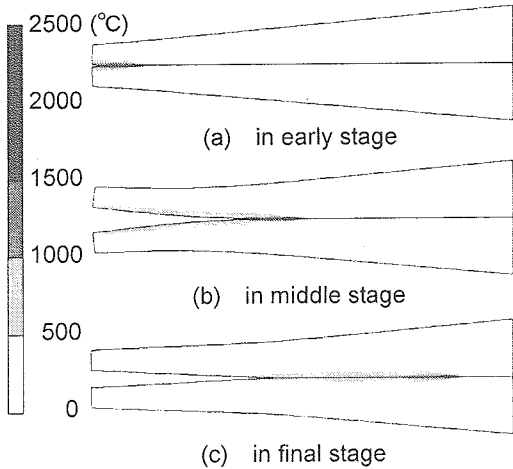

Fig.6 Transient temperature distribution and deformation.

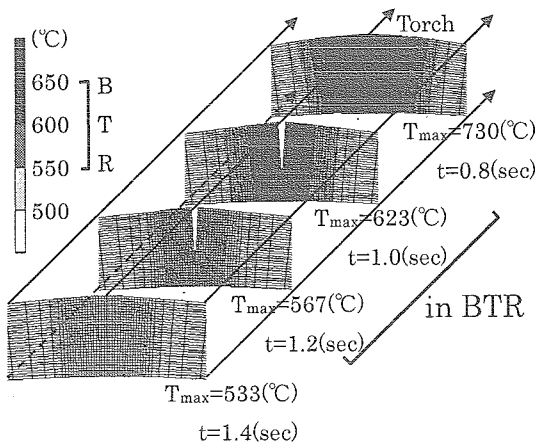

Fig.7 Temperature distribution and deformation with cracking in Trans-Varestraint test specimen after complete loading.

tests. In the Houldcroft test, there are two types using Fish Bone specimens where the difference is the choice of the direction of welding. In both types, the hot cracking susceptibility is evaluated by the crack length. In the Trans- Varestraint test, the bending strain is applied on the test specimen during bead on plate welding, and the susceptibility is evaluated from the strain and the temperature when the crack is formed. The proposed FEM employing the temperature dependent interface element is applied to the analyses of those tests.

Figure 6 shows transient temperature distribution and deformations during the welding in the Houldcroft test of mild steel, where the specimen is a simplified Fish Bone specimen which is a narrow trapezoidal plate without fins. It is clearly observed that the crack stops extending at the middle of the plate while the torch keeps moving. On the other hand, Fig.7 shows the temperature distributions in the Trans-Varestraint test of aluminum alloy superposed on the deformed geometry, including the hot cracking for sections corresponding to every 0.2

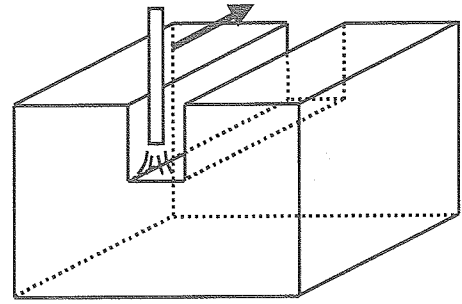

Fig.8 Schematic illustration of narrow gap welding.

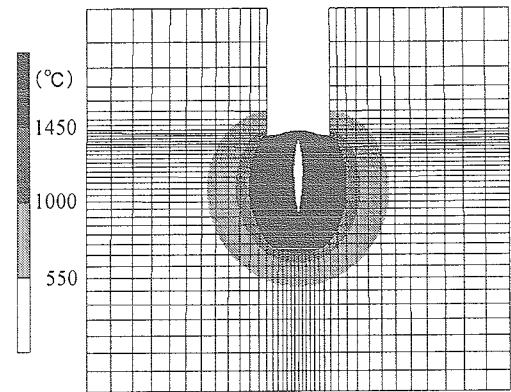

Fig.9 Maximum temperature distribution and deformation with pear-shaped bead cracking..

sec. from 0.8 sec. after the moment when the torch passes each section. In Fig.7, the maximum temperature on each section is shown together with the time. In the cases of  $t = 1.0$  and  $1.2$  sec., the crack is observed and the temperature along the centerline is within the BTR during the loading process.

In addition to these simulations, the proposed method is applied to the narrow gap welding of SM490 for examining practical engineering problems as shown in Fig.8. As an example of the calculation results, the maximum temperature distribution and the deformation after complete cooling is shown in Fig.9. The area above  $1450$  °C represents the penetration where the metal is melted. As shown in Fig.9, the pear-shaped bead cracking is formed. From these computations, it is verified that the proposed method has a great potential as a tool to study the hot cracking problems. Because of a limitation of paper length, the details of those computations are reported elsewhere<sup>4-7</sup>.

#### 4. Conclusions

In order to theoretically clarify the mechanism of hot cracking, a FEM employing a temperature dependent interface element is developed. It is applied to analyze the Houldcroft type test, Trans-Varestraint test and the narrow gap welding. Based on a series of computations, the potential usefulness of the proposed method is demonstrated.

## Theoretical Prediction of Welding Hot Cracking and Its Control

### References

- 1) T. Senda and F. Matsuda : Trans. of J.W.S., 41 (1972), p.113.
- 2) K. Nakata and F. Matsuda : Trans. of JWRI, 24 (1995), p.83.
- 3) Z.Q. Wu, H. Serizawa and H. Murakawa, Key Engineering Materials, 166 (1999), p.25.
- 4) M. Shibahara, H. Serizawa and H. Murakawa, Trans. of JWRI, 29 (2000), p.59.
- 5) M. Shibahara, H. Serizawa, H. Murakawa and Y. Ueda, Proc. 11th Int. Offshore and Polar Eng. Conf., (2001), p.297.
- 6) M. Shibahara, H. Serizawa and H. Murakawa, Proc. 13th Int. Offshore and Polar Eng. Conf., Vol.IV (2003), p.195.
- 7) M. Shibahara, S. Itoh, W. Liang and H. Murakawa, Proc. 13th Int. Offshore and Polar Eng. Conf., Vol.IV (2003), p.135.